

Asia's Innovative Technology Showcase for Security, Building and Electrical Engineering Industries

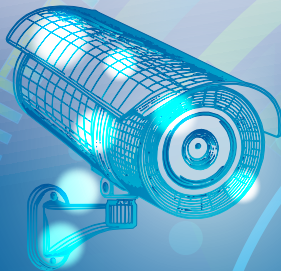

Build4Asia 2025

Build4Asia — Asia's Innovative Technology Showcase for Security, Building and Electrical Engineering Industries is set to embark on an exciting new chapter in 2025. Themed with **"Charting the Hybrid Landscape for Smart City Advancement"**, Build4Asia 2025 will **co-locate with three other leading technology-focused exhibitions** to sharpen its focus on cutting-edge technologies, expand its impact across Asia while delivering the same level of excellence the show is known for.

To take advantage of this new direction, the event will now take place from **15-17 July 2025** strategically at **AsiaWorld-Expo**, to benefit from the proximity of Hong Kong International Airport and Hong Kong-Zhuhai-Macao Bridge to welcome regional participants from the Greater Bay Area and the rest of Asia.



Boarder Showcase of Technological Prowess

Complementing the core focus on building and security technologies, the expo ventures into related fields including advanced batteries, energy storage, green installations, fuel cells and data center solutions, offering a comprehensive vision for a smarter, more resilient, and environmentally conscious city.



Expanded Reach to a Diverse Audience

The co-location boasts an expanded visitor base through the convergence of expertise, drawing visitors from diverse sectors including building management, sustainability, IT, security, investors and more to cultivate a rich ecosystem for collaboration and innovation.



Pioneering Cross-Industry Innovations and Insights

Industry movers and shakers across the building, energy, sustainability, and data center sectors will come together in a series of seminars and networking events, exploring on how cross-sector technological advancements can drive transformation in each industry.



Strategic Location for Unmatched Connectivity

Relocating to AsiaWorld-Expo, a premier venue strategically positioned near Hong Kong International Airport and the Guangdong-Zhuhai-Macao Bridge, the expo ensures seamless connectivity to a global audience, cementing its position as Asia's tech powerhouse.



600+
Exhibitors & Brands



100+
Educational Seminar
Sessions



2,000+
Products & Solutions



Featured Exhibition Zones



- Cables, Cable Glands & Cable Trays
- Circuit Breakers
- Commercial & Office Lightings
- Connectors / Connecting System
- Controls & Dimmers
- Daylight Technologies
- Decorative & Custom Fixtures
- Electrical Power Distribution & Transmission
- Emergency Lighting & Safety Signs
- Fiber Optic Lightings
- Fire Safety Products
- General Lighting
- Lamps, Energy Saving Lamps
- LED Lighting Solutions
- Lightning Protection Systems & Earth Rods
- Meter & Monitoring Systems
- Motors & Motor Controls
- Outdoor & Street Lightings
- Power Generation Equipment / Generators
- Renewable Energy Technologies Switches
- Testing & Measuring Instruments for Power
- Thermal Imaging & Infrared Cameras Transformers
- Wireless Solution



- Air Filtration Equipment
- Air-Conditioning Solutions
- Architectural / Interior / Landscape Design & Service
- Architectural Lighting
- Building & Interior Decorative Material
- Building Management Solution
- Building Paint & Coating
- Ceiling / Flooring / Wall Covering / Fabric / Carpet
- Communication Solution
- Energy Efficiency Solution
- Energy Saving / Insulation / Heat Preservation Material
- Facility Management System

- Fireproof Material
- Furniture & Soft Furnishing
- Heating, Ventilation, and Air Conditional (HVAC)
- Home Automation Solution
- Intelligent Building Solution
- Lighting Control Solution
- Network Management Solution
- Pipe & Fitting
- Sustainable / Green Building & Construction Material
- Water / Environmental Management Technology
- Waterproof Material / Roofing & Ceiling



- Access Control
- Biometrics
- Car Parking System
- Cash Management Solution
- CCTV & Remote Monitoring Control Systems
- Electronic Article Surveillance (EAS)
- Electronic Safety
- Fire Safety Solutions
- Home Automation Security Solution
- Information / Data Security
- Integrated Security Management Systems
- Intelligent Buildings
- Intruder Alarm Solution
- IP Security
- Lock Sales
- Meter Detectors & X-ray / Screening Equipment
- Rescue & Emergency Equipment
- Safety Clothing
- Security Doors, Gates & Shutters
- Security Guard Services
- Security Solutions
- Smartcard / Card Technology
- Surveillance Solutions
- Traffic Counting Solutions
- Transportation Security

Build4Asia 2024 Buyer's Profile



4,600+
Trade Buyers



31%
Countries & Regions



89% Hong Kong
11% International

Business Nature of Buyers



Job Function of Buyers

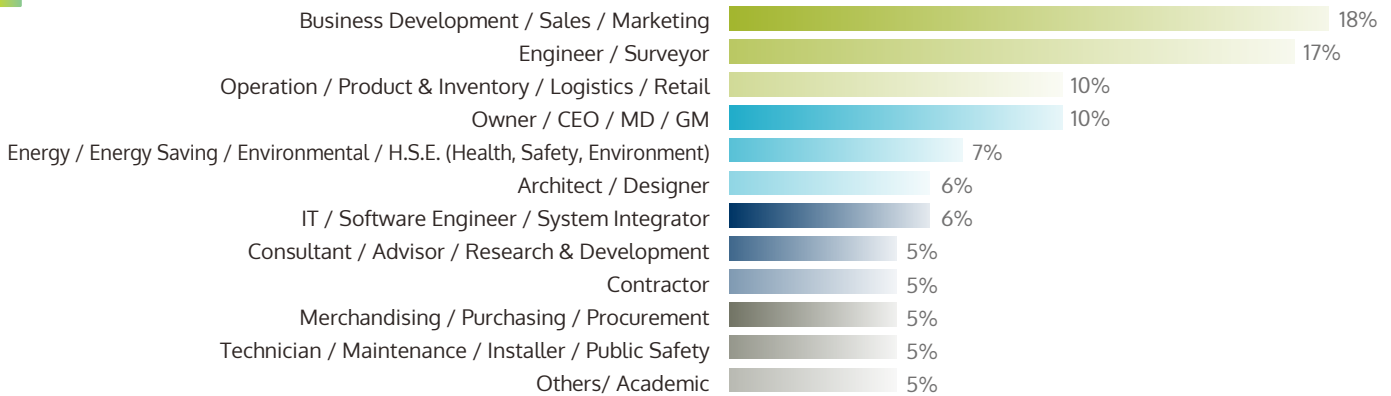

Visting Countries & Regions

- Mainland China
- Macau S.A.R.
- Philippines
- Singapore
- Malaysia
- Thailand
- Mongolia
- South Korea
- USA
- Vietnam
- Russia
- Taiwan (China)
- Japan
- Indonesia
- And more...

Participating in Build4Asia has always resulted in meaningful business connections and partnerships for our company. We are delighted to see that the exhibition is improving each year, drawing a more diverse audience with increasingly constructive networking events.

acelab
technology

C.C. Poon
Director, Acelab Technology Limited



2024 Visiting Companies

3M
AAHK
AECOM
Aegis Engineering Co. Ltd.
Airport Authority Hong Kong
Architectural Services Department
ArchSD, HKSARG
Arup
Asia Pacific RIM (China) Limited
Asia Pacific Security Association
Asian Institute of Intelligent Buildings
Asian Professional Security Association -
Hong Kong Chapter
AsiaWorld-Expo Management Limited
ASTRI (Hong Kong Applied Science and
Technology Research Institute)
ATAL Engineering Group
Atkins China Limited
Baguio Green Technology Limited
BEAM Society Limited
Best Western Hotel
Building Services Operation and
Maintenance Executives Society
CABE Hong Kong
CAN Design
Cargo Services Far East
CBRE
Central Plaza Management Co. Ltd.
Chartered Institution of Building Services
Engineers Hong Kong Region
Cheung Kong Center Property Management
Limited
China State Construction Engineering
(Hong Kong) Limited
Chinachem Group
CHKC Building Management Limited
Chubb Hong Kong Limited
Chun Wo Construction & Engineering
Citic Telecom International Holdings
Limited
Citybase Property Management Limited
Citybus
CLP
Construction Industry Council
ConTech Point Company Limited
Cornerstone Technologies
Country House property management
limited
Critical Infrastructure Security Coordination
Centre
Dah Chong Hong Motor Leasing Ltd.
Electrical & Mechanical Services
Department
Environmental Protection Department
Fordex Electric Co Ltd.
Four Seasons Hotel Hong Kong
G4S
Gammon construction
GBA Carbon Neutrality Association
GELEC (HK) Limited
GHM Greater Bay Area Institute of Urban
Architecture (Hong Kong)
Global Payments
Global Switch Hong Kong Limited
Goodwell Property Management limited
Government Logistics Department
Great Eagle Group of Company
Harbour City Estates Limited
Harriman Property Management Limited
Henderson Land
Hip Hing Construction Company Limited
Hip Seng Construction Company Limited

HK & China Gas Company Ltd.
HK Electric
HKCIC
HKT
Honeywell limited
Hong Kong Association of Energy
Engineers
Hong Kong Baptist University
Hong Kong Cyberport Management
Company Limited
Hong Kong Disneyland
Hong Kong Disneyland Hotel
Hong Kong Electrical Contractors'
Association
Hong Kong Gold Coast Hotel
Hong Kong Green Building Council
Hong Kong Housing Society
Hong Kong Institute of Construction
Hong Kong Institution of Engineers
- Gas & Energy Division
Hong Kong Jockey Club
Hong Kong Metropolitan University
Hong Kong Ocean Park Marriott Hotel
Hong Kong Police Force
Hong Kong Polytechnic University
Hong Kong Productivity Council
Hongkong Land Limited
Hotel Jen Hong Kong
Hospital Authority
Hutchison Property Management
Company Limited
Hutchison Telecommuication Hong
Kong Limited
Hyatt Hotels Corporation
ibis Hong Kong Hotel
International Facility Management
Association Hong Kong Chapter
ISS Facility Services Ltd.
Jardine engineering Corporation
Jetford Engineering and Trading Co. Ltd.
JLL Hong Kong
Jones Lang LaSalle Management Service
Limited
K&W Architects Limited
K. Wah Management Services Ltd.
Kadoorie Estates Limited
Kai Shing Management Services Limited
Kerry Hotel, Hong Kong
Kerry Property Management Services
Limited
Lai Sun Development
Laws Group
Lead8
Leigh & Orange Limited
Leighton Contractors (Asia) Ltd.
Lenovo PCCW Solutions
Liebherr (HKG) Limited
Lik Kai Engineering Company Limited
Lik On Security Ltd.
Link Asset Management Limited
Long Engineering Management Limited
Mattex Asia development Limited
Marco Polo Hong Kong Hotel
Mitsubishi Electric (HK) Limited
MTR
Nan Fung Development Ltd.
New World Development Company
Limited
Newland Engineering Limited
Nina Hotel Island South
Ocean Park Corporation

Orientop Building Material Limited
Otis Elevator (HK) Ltd.
Ove Arup & Partners Hong Kong Ltd.
Overseas Chinese Development
(Hong Kong) Co., Ltd.
P&T Architects and Engineers Ltd.
Paliburg Development Consultants Limited
Paul Y. Engineering Group
PCCW
Peak Tramways Company, Limited
Perfect World Company Limited
REC Engineering Company Limited
Renaissance hotel
Ronald Lu & Partners
Royal Plaza Hotel
S.H.K. Real Estate Management Co. Ltd.
Saint-Gobain Weber (Hong Kong) Building
Material Co., Ltd
Samson Wong & Associates Property
Consultancy Ltd.
Sanfield (Management) Limited
Savills Property Management Limited
Schneider Electric
SGS Hong Kong Ltd.
Sheraton Hong Kong Hotel
Shine Union Limited
SHKP
Shun Hing Engineering Contracting Co Ltd.
Siemens Limited
Sika Hongkong Ltd.
Sino Group
Sino Supreme Engineering Limited
Sun Hung Kai Properties
Swire Properties
The Hong Kang & China Gas Company
Limited
The Hong Kong Institute of Architects
The Hong Kong Institute of Surveyors
The Hong Kong Jockey Club
The Hong Kong Electric Co. Ltd.
The Jardine Engineering Corporation,
Limited
The Kimberley Hotel
The Murray Hong Kong
The Parklane Hong Kong
The Peninsula Hotels
The University of Hong Kong
Thomas Anderson & Partners Consulting
Engineers Ltd.
Times Square Ltd.
TK Elevator Hong Kong Limited
Towngas
Tung Wah Group of Hospitals
TÜV Rheinland Hong Kong Ltd.
UPS
Viewco Building Services & Engineering
Company Limited
Wharf Hotels Management Limited
West Kowloon Cultural District Authority
Wheelock Properties (Hong Kong) Limited
WSP
Wynn Macau
YMCA of Hong Kong
And more...

Past Onsite Events Highlights



Asian Securitex Conference



Build4Asia Conference



100+
Educational
Seminar Sessions



90+
Speakers lined-up



Build4Asia Forum



Build4Asia Awards



IFMA – HK Chapter Integrate Conference

The quality of buyers at Build4Asia is outstanding. Besides the buyers are interested in our BESS, eMobility Charging as a Service and Green Home Solutions, some government officials also visited our booth to know more about how BESS help to enhance efficiency and sustainability. Having access to such high-calibre buyers ensures that our exhibiting efforts turn into tangible business opportunities.

CLP_e
中電源動

Regina Yip
Head of Sales, CLPe Solutions Limited



Extensive Promotional Campaigns

Our exhibitors have access to a comprehensive lineup of promotional campaigns to ensure their products and messages reach the targeted audience and generate successful leads.



Website



Social Media



E-newsletter



Direct Mailing



VIP Nomination



Telemarketing



Trade Magazine, Newspaper
and Online Media

Strong Industry Support at Build4Asia 2024

As the key industry event, Build4Asia is supported by leading associations and partners across Hong Kong, Macau, Mainland China, and Asia, owing to its professionalism and comprehensive high-quality offerings, which fosters responsiveness within the industry.

Major Supporters

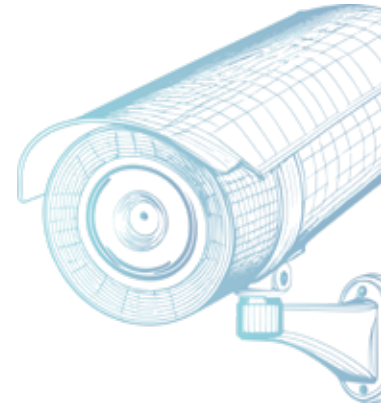

Supporting Associations



Media Partners



2025 Exhibiting Packages



Space Only (min. 18m²)

US \$530/ m²

Bare floor space, ideal for large exhibitions or national groups who wish to build their own stand



Walk-on Package (min. 9m²)

US \$580/ m²

Walls, carpet, lighting, fascia, power point, counter and chairs are included



Premium Package (min. 18m²)

US \$620/ m²

Wall, carpet, lighting, fascia, company logo, power point, counter, lockable cabinet, display shelves, table & chairs are included



SME Promotion Funding

Hong Kong Eligible Exhibitors are entitled to apply the "SME Promotion Funding" to **save up exhibiting costs or HK\$100,000 subsidy** for Build4Asia 2025. For details, kindly visit <http://www.smefund.tid.gov.hk>



Sponsorship Opportunities

Build4Aisa offers various high-impact sponsorship opportunities to help your company amplify its visibility and engagement with attendees, providing you with enhanced branding, lead generation and networking advantages. Sponsorship options include, but not limited to, visitor lanyard, show bag, souvenir, cyber kiosk, VIP lounge and onsite events. Contact us for more information.

Co-located With



www.datacenter-asia.com



www.thebatteryshow.asia



www.mobilitytech.asia



📍 17/F, China Resources Building,
26 Harbour Road, Wanchai, Hong Kong

☎ +852 3709 4583
✉ exhibit@build4asia.com

Informa Markets creates platforms for industries and specialist markets to trade, innovate and grow. Our portfolio is comprised of more than 550 international B2B events and brands in markets including Healthcare & Pharmaceuticals, Infrastructure, Construction & Real Estate, Fashion & Apparel, Hospitality, Food & Beverage, and Health & Nutrition, among others. We provide customers and partners around the globe with opportunities to engage, experience and do business through face-to-face exhibitions, specialist digital content and actionable data solutions. As the world's Leading exhibitions organiser, we bring a diverse range of specialist markets to life, unlocking opportunities and helping them to thrive 365 days of the year. For more information, please visit www.informamarkets.com.